

Illinois Department of Transportation
 Bureau of Materials and Physical Research
**APPROVED/QUALIFIED PRODUCT LIST OF REINFORCING BAR SPLICER ASSEMBLIES AND MECHANICAL
 SPLICERS**

February 28, 2014

This list supersedes the October 18, 2013 list.

Standard Specifications for Road and Bridge Construction, Section 508.06(b)(c) (Adopted January 1, 2007)

Material Code: 63203/63204

For information regarding new product submittal, click the “New Submittal” bookmark to the left.

<p>BarSplice Products, Inc. 4900 Webster Street Dayton, OH 45414 Producer Number: 3989-01 System Type: Mechanical “Bargrip” “Bargrip XL” “Bargrip UXL” “Grip-Twist” “ZAP Screwlok SL” “ZAP Screwlok TYP 2”</p> <p>System Type: Bar Splicer “Barsplicer”</p> <p>http://www.barsplice.com/</p>	<p>CMC Rebar Illinois 780 East Industrial Parkway Kankakee, IL 60901 Producer Number: 3453-03 System Type: Bar Splicer “BPI Standard Barsplicer System”</p> <p>http://www.cmc.com/en/americas/Pages/home.aspx</p>
<p>Dayton Superior Corporation 721 Richards Street Miamisburg, OH 45342 Producer Number: 494-01 System Type: Mechanical “D-250 L” “D-250 S”</p> <p>System Type: Bar Splicer “D-50 DBR” “DB-SAE System” “US/MC”</p> <p>http://www.daytonsuperior.com/#</p>	<p>Erico Products, Inc. 34600 Solon Road Cleveland, OH 44139 Producer Number: 2233-02 System Type: Mechanical “T-series (Cadweld)”</p> <p>System Type: Bar Splicer “Lenton Taper Thread A-2” “Lenton Form Saver”</p> <p>http://www.erico.com/products.asp?folderid=45</p>
<p>Fabco LLC 7410 Apache St. Houston, TX 77028 Producer Number: 6647-01 System Type: Bar Splicer “Multiple Piece Tie Bar System” “Form Saver Coupler”</p> <p>http://www.fabcous.com/</p>	<p>Fischer Construction Systems, Inc. 688 North Broadway St. Louis, MO 63147 Producer Number: 5555-01 System Type: Mechanical T-series (Cadweld)”</p> <p>System Type: Bar Splicer “Lenton Form Saver” “Lenton Taper Thread A-2”</p> <p>http://www.fcsconstruction.com/form.html</p>

Midwest Pipe & Rebar Coating 925 Kennedy Avenue Scherverville, IN 46375 Producer Number: 2918-01 System Type: Bar Splicer “BPI Standard Barsplicer System” http://www.midwestpiperebar.com/	Williams Form Engineering 1501 Madison Avenue SE Grand Rapids, MI 49507 Producer Number: 4225-01 System Type: Bar Splicer “C2D Flange” http://www.williamsform.com/
----------------------------------------------------------------------------------------------------------------------------------------------------------------------------------------------------------------------------------------------------------------------------	------------------------------------------------------------------------------------------------------------------------------------------------------------------------------------------------------------------------------------------------

System types “Bar Splicer” or “Mechanical” are required when used as splices outlined on Bridge Manual Base Sheet BSD-1. The “Mechanical” system requires skilled labor and/or unique equipment to install where the “Bar Splice” system consists of threaded reinforcing bars which screw into the splicer.

To view detailed information and photos click the “Splicer Guide” bookmark to the left.

Domestic Steel Act Applies:

All iron and steel products, which are to be incorporated into state projects shall be domestically manufactured or produced and fabricated. The Contractor shall obtain from the iron or steel producer and/or fabricator, in addition to the mill analysis, a certification that all iron or steel materials meet these domestic source requirements. The application of all coatings, epoxy, galvanizing, painting, etc., to metal products shall be domestically applied.

Approved Reinforcing Bar Splicer Drawing Guide

P/S#	P/S Name	City, State	Eff Date	Status
------	----------	-------------	----------	--------

3989-01

3989-01	BarSplice Products, Inc.	Dayton, OH	04/02/07	Appr
---------	--------------------------	------------	----------	------

System Type: Mechanical

Bargrip System Standard Ty-1 - Line color will determine bar size.



Coupler	Length 'L' (in)	Coupler Weight (lb)	Color Code	Rebar Size	Outside Dia. 'D' (in)	Inside Dia. 'd' (in)	Insertion Bar 'i' (in)
3	2	0.16	Orange	3	3/4	1/2	1
4	2 1/2	0.25	Pink	4	1 1/16	5/8	1 1/4
5	3 1/8	0.46	Red	5	1 1/8	3/4	1 9/16
6	3 3/4	0.85	Yellow	6	1 3/8	15/16	1 7/8
7	4 3/8	1.24	Blue	7	1 9/16	1 1/16	2 3/16
8	5	1.84	Black	8	1 3/4	1 3/16	2 1/2
9	5 1/2	2.42	Red	9	1 15/16	1 3/8	2 3/4
10	6 5/16	3.46	Yellow	10	2 3/16	1 1/2	3 1/8
11	6 7/8	4.38	Blue	11	2 3/8	1 11/16	3 7/16
14	8 3/4	9.47	Pink	14	2 15/16	1 15/16	4 3/8
18	12	20.6	Red	18	3 13/16	2 5/8	6

P/S#	P/S Name	City, State	Eff Date	Status
------	----------	-------------	----------	--------

3989-01 BarSplice Products, Inc. Dayton, OH 04/02/07 Appr

System Type: Mechanical

Bargrip UXL Ty-2 Series - Line color will determine bar size.



Coupler	Length 'L' (in)	Coupler Weight (lb)	Color Code	Rebar Size	Outside Dia. 'D' (in)	Inside Dia. 'd' (in)	Insertion Bar 'i' (in)
3	4 1/2	0.36	Orange	3	3/4	1/2	2 1/4
4	5 1/4	0.52	Pink	4	15/16	5/8	2 5/8
5	6	0.87	Red	5	1 1/8	3/4	3
6	6 3/4	1.53	Yellow	6	1 3/8	15/16	3 3/8
7	7 1/2	2.11	Blue	7	1 9/16	1 1/16	3 3/4
8	8 1/2	3.12	Black	8	1 3/4	1 3/16	4 1/4
9	9 1/4	4.07	Red	9	1 15/16	1 3/8	4 5/8
10	10	5.47	Yellow	10	2 3/16	1 1/2	5
11	10 3/4	6.85	Blue	11	2 3/8	1 11/16	5 3/8
14	13	14.1	Pink	14	2 15/16	1 15/16	6 1/2
18	16	27.5	Red	18	3 13/16	2 5/8	8

P/S#	P/S Name	City, State	Eff Date	Status
------	----------	-------------	----------	--------

3989-01 BarSplice Products, Inc. Dayton, OH 04/02/07 Appr

System Type: Mechanical

Bargrip XL Ty-2 Series - Line color will determine bar size.



Coupler	Length 'L' (in)	Coupler Weight (lb)	Color Code	Rebar Size	Outside Dia. 'D' (in)	Inside Dia. 'd' (in)	Insertion Bar 'i' (in)
3	3 ¼	0.26	Orange	3	¾	½	1 ⅝
4	4	0.40	Pink	4	1 ⅜	⅝	2
5	4 ¾	0.69	Red	5	1 ½	¾	2 ⅜
6	5 ½	1.25	Yellow	6	1 ⅝	1 ⅜	2 ¾
7	6 ¼	1.76	Blue	7	1 ¾	1 ½	3 ⅛
8	7	2.57	Black	8	1 ¾	1 ⅜	3 ½
9	7 ½	3.30	Red	9	1 ⅞	1 ⅝	3 ¾
10	8 ¼	4.52	Yellow	10	2 ⅜	1 ½	4 ⅛
11	9	5.73	Blue	11	2 ⅝	1 ⅞	4 ½
14	11	11.9	Pink	14	2 ⅞	1 ⅞	5 ½
18	14	24.1	Red	18	3 ⅜	2 ⅝	7

P/S#	P/S Name	City, State	Eff Date	Status
------	----------	-------------	----------	--------

3989-01 BarSplice Products, Inc. Dayton, OH 04/02/07 Appr

System Type: Mechanical

Grip-Twist System.



REBAR SIZE	TAPER GRIP-TWIST COLOR CODE	COUPLER WEIGHT (lb)		DIMENSIONS (inches)					
				BAR INSERTION after swaging		REBAR GAP G	MALE INSERTION H	END ALLOWANCE A	Non-Swaged LENGTH N
				FEMALE F	MALE M				
3	Orange	0.19	0.17	1 3/8	1 3/8	1 1/2	9/16	1	1 1/8
4	Pink	0.30	0.30	1 3/4	1 3/4	1 3/4	3/4	1 3/16	1 5/16
5	Red	0.53	0.52	2 1/4	2 3/16	1 7/8	15/16	1 3/8	1 9/16
6	Yellow	1.00	0.90	2 3/4	2 5/8	2 1/8	1 1/8	1 9/16	1 13/16
7	Blue	1.50	1.40	3 1/8	3 1/16	2 1/2	1 5/16	1 7/8	2 1/8
8	Black	2.10	2.00	3 9/16	3 1/2	2 7/8	1 1/2	2 1/8	2 3/8
9	Red	2.85	2.85	4	3 15/16	3 1/4	1 3/4	2 7/16	2 3/4
10	Yellow	4.05	4.00	4 1/2	4 3/8	3 5/8	2	2 3/4	3 1/8
11	Blue	4.90	5.00	4 7/8	4 13/16	3 1/2	2 1/8	2 3/4	3 1/8
14	Pink	9.05	9.10	6 1/16	5 7/8	4 3/8	2 1/2	3 5/16	3 7/8
18	Red	20.3	21.2	7 7/8	7 5/8	5 5/8	3 1/4	4 5/16	5 1/16

P/S#	P/S Name	City, State	Eff Date	Status
------	----------	-------------	----------	--------

3989-01 BarSplice Products, Inc. Dayton, OH 04/02/07 Appr

System Type: Mechanical

Zap Screwlok SL Series.



Coupler Size	Coupler Weight (lb)	Length 'L' (in)	'A' (in)	'B' (in)	'C' (in)	'X' (in)	Number Screws per Bar	Average Torque (ft-lbs)
4	1.5	5	1 1/16	1/16	1/2	1 3/8	2	50
5	2.6	7	1 1/8	3/8	5/8	1 5/8	3	50
6	3.8	9	1 3/16	5/16	11/16	1 3/4	4	50
7	6.2	10 3/4	1 1/4	1 1/16	13/16	2 1/16	4	100
8	9.3	13	1 5/16	1 1/16	7/8	2 1/4	5	100
9	14.3	13 7/8	1 5/8	1 1/4	1 1/16	2 5/8	4	200
10	18.2	16 1/2	1 11/16	1 3/16	1 1/8	2 3/4	5	200
11	22.3	19 1/8	1 13/16	1 1/2	1 3/4	2 13/16	6	200
14	26.0	13	2 5/16	1 3/4	1 1/2	3 3/4	7	350
18	58.4	23 1/2	2 1/2	2 1/4	1 13/16	4 3/8	16	350

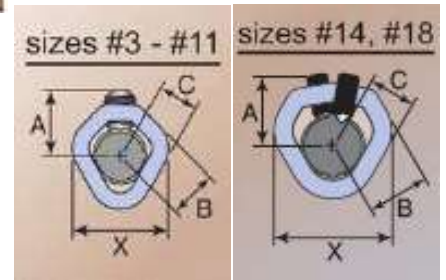

P/S#	P/S Name	City, State	Eff Date	Status
------	----------	-------------	----------	--------

3989-01 BarSplice Products, Inc. Dayton, OH 04/02/07 Appr

System Type: Mechanical

Zap Screwlok Type 2 Epoxy Series.



Coupler Size	Coupler Weight (lb)	Length 'L' (in)	'A' (in)	'B' (in)	'C' (in)	'X' (in)	Number Screws per Bar	Average Torque (ft-lbs)
3	1.0	5	1 ³ / ₁₆	5/8	7/16	1 1/8	2	50
4	2.2	7	1 1/16	1 ¹ / ₁₆	1/2	1 3/8	3	50
5	3.4	9	1 1/4	3/4	5/8	1 5/8	4	50
6	4.7	11	1 3/16	1 ³ / ₁₆	1 ¹ / ₁₆	1 3/4	5	50
7	7.6	13	1 1/4	1 1/16	1 ³ / ₁₆	2 1/16	5	100
8	10.9	15 1/4	1 5/16	1 1/8	3/8	2 1/4	6	100
9	17.6	16 3/4	1 5/8	1 1/4	1 1/16	2 5/8	6	200
10	21.4	19 1/8	1 11/16	1 7/16	1 1/8	2 3/4	7	200
11	25.4	21 1/2	1 13/16	1 1/2	1 1/4	2 15/16	8	200
14	31.7	15 3/8	2 3/16	1 3/4	1 1/2	3 1/4	9	350

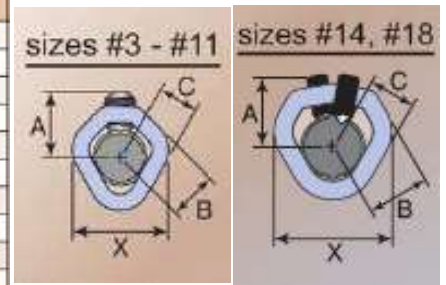

P/S#	P/S Name	City, State	Eff Date	Status
------	----------	-------------	----------	--------

3989-01 BarSplice Products, Inc. Dayton, OH 08/24/2012 appr

System Type: Bar Splicer

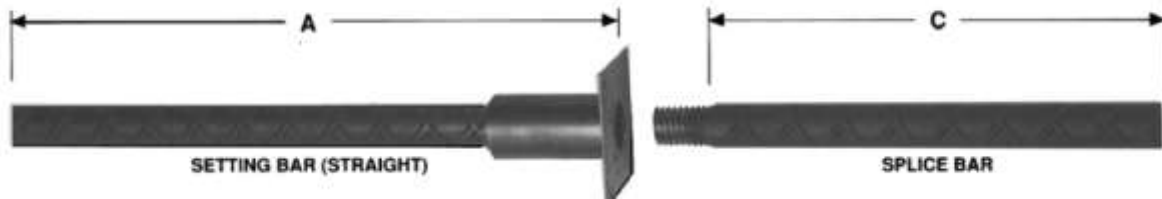

BPI® BARSPLICER FLANGED COUPLER

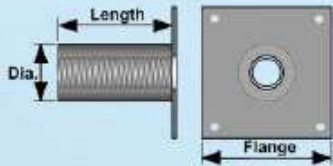

REBAR SIZE	THREAD SIZE	WEIGHT (lbs)	LENGTH (in)	DIAMETER (in)	FLANGE (in)	BEVEL (in)
4	½ - 13 UNC	0.28	1 ¾	7/8	2 x 2	-
5	5/8 - 11 UNC	0.35	2	1	2 x 2	-
6	¾ - 10 UNC	0.40	2 1/8	1 1/8	2 x 2	-
7	7/8 - 9 UNC	0.50	2 ½	1 ¼	2 x 2	-
8	1 - 8 UNC	0.90	3	1 ½	2 x 2	-
9	1 1/8 - 7 UNC	1.50	3 ½	1 ¾	3 x 3	-
10	1 ¼ - 7 UNC	2.35	4	2	3 x 3	-
11	1 3/8 - 6 UNC	2.40	4 ½	2	3 x 3	-

P/S#	P/S Name	City, State	Eff Date	Status
------	----------	-------------	----------	--------

3453-03

3453-03 CMC Rebar Illinois Kankakee, IL 08/24/12 Appr

System Type: Bar Splicer

CMC is a producer of the BPI Standard Barsplicer System from BarSplice Products.

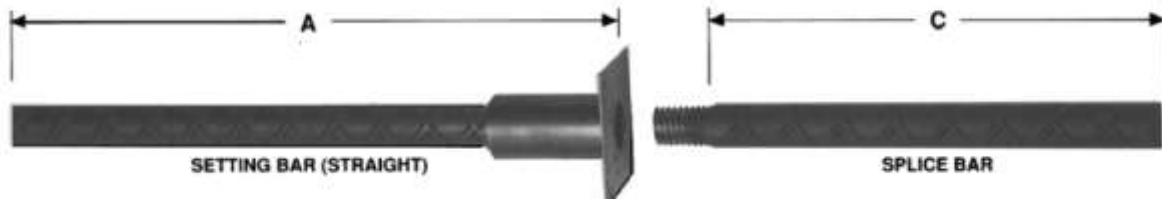

BPI® BARSPLICER FLANGED COUPLER		REBAR SIZE	THREAD SIZE	WEIGHT (lbs)	LENGTH (in)	DIAMETER (in)	FLANGE (in)	BEVEL (in)
	4	½ - 13 UNC	0.28	1 ¾	7/8	2 x 2	-	
	5	5/8 - 11 UNC	0.35	2	1	2 x 2	-	
	6	¾ - 10 UNC	0.40	2 1/8	1 1/8	2 x 2	-	
	7	7/8 - 9 UNC	0.50	2 ½	1 ¼	2 x 2	-	
	8	1 - 8 UNC	0.90	3	1 ½	2 x 2	-	
	9	1 1/8 - 7 UNC	1.50	3 ½	1 ¾	3 x 3	-	
	10	1 ¼ - 7 UNC	2.35	4	2	3 x 3	-	
11	1 ¾ - 6 UNC	2.40	4 ½	2	3 x 3	-		

P/S#	P/S Name	City, State	Eff Date	Status
------	----------	-------------	----------	--------

494-01

494-01 Dayton Superior Corp. Miamisburg, OH 04/02/07 Appr

System Type: Bar Splicer

D-50 DBR Coupler System.

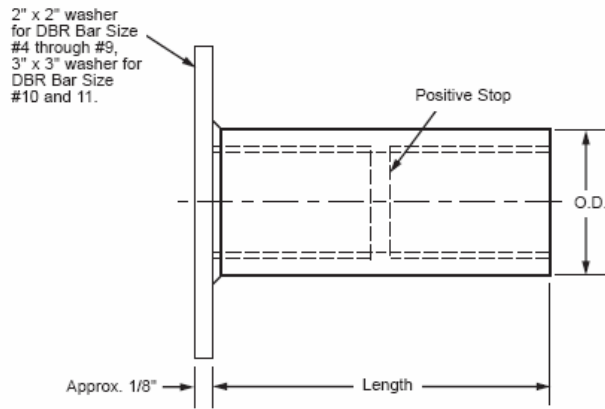
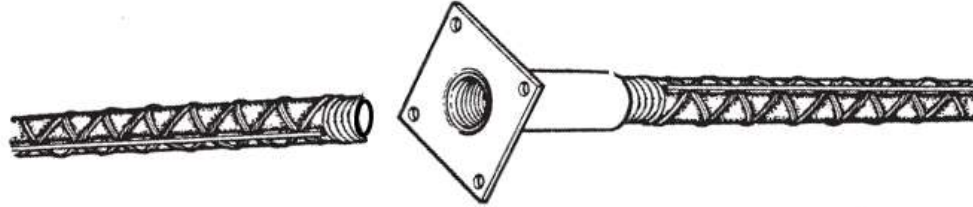

Bar Size Designation	Thread Data	O.D. x Length
#4 [#13]	1/2"-13 NC	3/4" x 1-7/8"
#5 [#16]	5/8"-11 NC	7/8" x 2"
#6 [#19]	3/4"-10 NC	1-1/16" x 2-3/8"
#7 [#22]	7/8"-9 NC	1-1/4" x 2-3/4"
#8 [#25]	1"-8 NC	1-3/8" x 3-1/8"
#9 [#29]	1-1/8"-8 UN	1-5/8" x 3-5/8"
#10 [#32]	1-1/4"-8 UN	1-3/4" x 4-1/8"
#11 [#36]	1-3/8"-8 UN	1-15/16" x 4-3/8"

Note: Threads on #9, #10 and #11 couplers are UN not NC.

P/S#	P/S Name	City, State	Eff Date	Status
------	----------	-------------	----------	--------

494-01 Dayton Superior Corp. Miamisburg, OH 04/02/07 Appr

System Type: Bar Splicer

DB-SAE Rebar System (Old Richmond Screw & Anchor P/S# 1650-01).

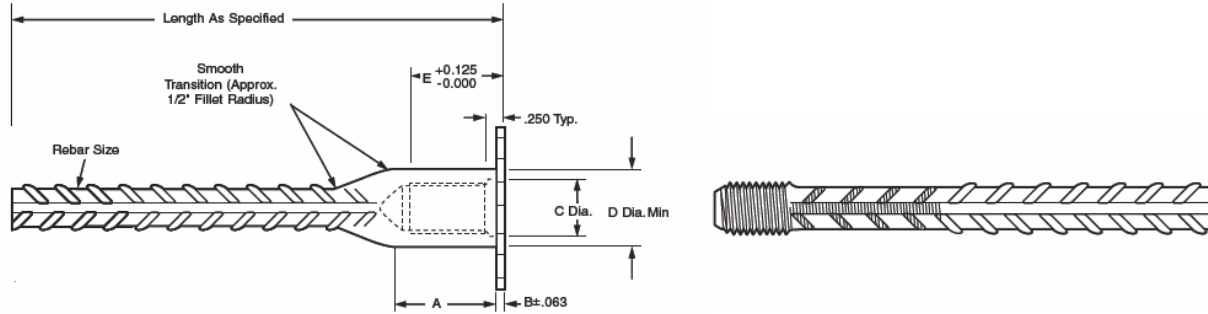

Bar Size	Thread Size	A	B	C	D	E	Flange Diameter	Minimum P_{ult} Range = 95% F_u Actual or 160% F_y Specified*
#4 [#13]	5/8"-11 UNC	1-1/8"	1/8"	11/16"	55/64"	1"	1-7/8"	19,200 lbs.
#5 [#16]	3/4"-10 UNC	1-9/16"	1/8"	13/16"	1-3/64"	1-1/8"	2-1/16"	29,760 lbs.
#6 [#19]	7/8"-9 UNC	1-11/16"	1/8"	15/16"	1-15/64"	1-1/4"	2-1/4"	42,400 lbs.
#7 [#22]	1"-8 UNC	1-27/32"	1/8"	1-1/16"	1-27/64"	1-3/8"	2-7/16"	57,600 lbs.
#8 [#25]	1-1/8"-8 UN	2-1/16"	1/8"	1-3/16"	1-19/32"	1-1/2"	2-5/8"	75,840 lbs.
#9 [#29]	1-1/4"-8 UN	2-3/16"	1/8"	1-5/16"	1-25/32"	1-5/8"	2-13/16"	96,000 lbs.
#10 [#32]	1-7/16"-8 UN	2-7/16"	1/8"	1-1/2"	2"	1-13/16"	3"	121,920 lbs.
#11 [#36]	1-9/16"-8 UN	2-9/16"	1/8"	1-5/8"	2-7/32"	1-15/16"	3-1/4"	149,760 lbs.

*Loads shown based on 160% f_y specified

P/S#	P/S Name	City, State	Eff Date	Status
------	----------	-------------	----------	--------

494-01 Dayton Superior Corp. Miamisburg, OH 04/02/07 Appr

System Type: Bar Splicer

US/MC (Old Richmond Screw & Anchor P/S# 1650-01).

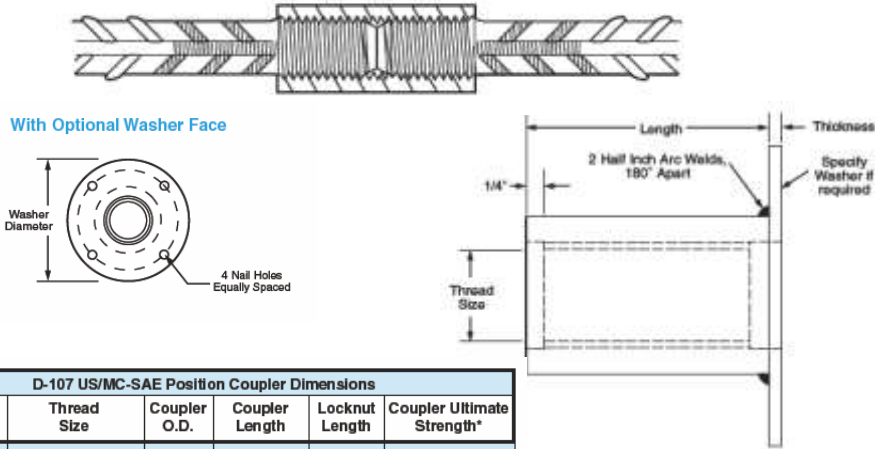

D-107 US/MC-SAE Position Coupler Dimensions					
Dowel-In Bar Size	Thread Size	Coupler O.D.	Coupler Length	Locknut Length	Coupler Ultimate Strength*
#4 [#13]	5/8" - 11 UNC	7/8"	2-1/8"	5/8"	19,200 lbs.
#5 [#16]	3/4" - 10 UNC	1-1/8"	2-1/2"	5/8"	29,760 lbs.
#6 [#19]	7/8" - 9 UNC	1-1/4"	2-3/4"	5/8"	42,240 lbs.
#7 [#22]	1" - 8 UNC	1-1/2"	3"	5/8"	57,600 lbs.
#8 [#25]	1-1/8" - 8 UN	1-5/8"	3-1/4"	3/4"	75,840 lbs.
#9 [#29]	1-1/4" - 8 UN	1-7/8"	3-1/2"	13/16"	96,000 lbs.
#10 [#32]	1-7/16" - 8 UN	2-1/8"	3-7/8"	15/16"	121,920 lbs.
#11 [#36]	1-9/16" - 8 UN	2-1/4"	4-1/8"	1"	149,760 lbs.
#14 [#43]	1-7/8" - 8 UN	2-3/4"	4-3/4"	1-1/4"	216,000 lbs.
#18 [#57]	2-1/2" - 8 UN	3-5/8"	6-1/2"	1-5/8"	384,000 lbs.

**Ultimate strength based on 160% f_y specified.

P/S#	P/S Name	City, State	Eff Date	Status
------	----------	-------------	----------	--------

2233-02

2233-02 Erico Products, Inc. Cleveland, OH 04/02/07 Appr

System Type: Bar Splicer

Lenton A-2. Part number stamped on splicer sleeve.

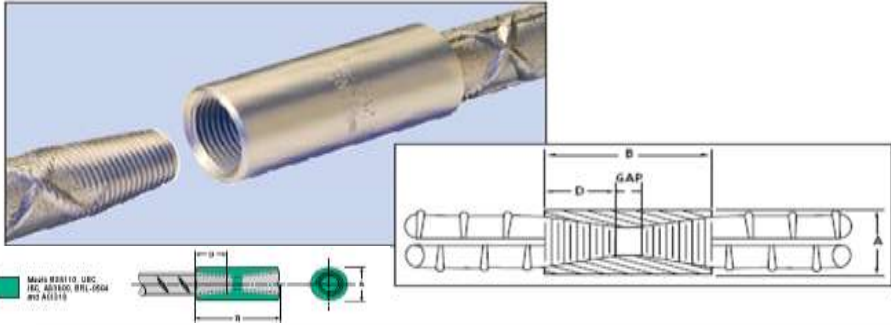

LENTON Standard Couplers - A2												
Inch lb	Rebar Size Metric	Designation Canadian	Soft Metric	Part No.	"A"		"B"		"D"		Weight	
					in	mm	in	mm	in	mm	lb	kg
4	12 mm	10M	13	EL12A2*	11/16	17	1-5/8	41	9/16	14	0.1	0.05
5	16 mm	15M	16	EL16A2*	7/8	22	2-3/16	56	7/8	22	0.3	0.14
6	20 mm	20M	19	EL20A2*	1-1/16	27	2-13/16	71	1-1/8	29	0.5	0.23
7	22 mm	-	22	EL22A2*	1-3/16	30	3-5/32	80	1-1/4	32	0.7	0.32
8	25 mm	25M	25	EL25A2	1-3/8	35	3-11/32	85	1-3/8	35	0.9	0.41
9	28 mm	30M	29	EL28A2	1-1/2	38	3-19/32	91	1-1/2	38	1.1	0.50
10	32 mm	-	32	EL32A2	1-3/4	44	3-25/32	96	1-9/16	40	1.5	0.68
11	36 mm	35M	36	EL36A2	1-7/8	48	3-31/32	101	1-11/16	43	1.7	0.77
-	40 mm	-	-	EL40A2	2-3/16	52	4-15/16	125	2-3/16	56	2.4	1.07
14	43 mm	45M	43	EL43TA2	2-1/4	57	5-1/4	133	2-1/8	54	3.3	1.50
-	50 mm	-	-	EL50A2	2-9/16	64	6-13/32	163	2-13/16	72	4.4	2.00
18	57 mm	55M	57	EL57TA2	3	76	6-1/2	165	2-3/4	70	6.4	3.08

* Use hex material (measured across the flats), others use round material.
 Bar dimensions and weights listed may vary by region. Coupler size not shown on these pages are available by special order. Contact your ERICO representative for more information on special sizes. Article numbers used in Europe, Middle East, Africa and Asia exclusively.

P/S#	P/S Name	City, State	Eff Date	Status
------	----------	-------------	----------	--------

2233-02 Erico Products, Inc. Cleveland, OH 04/02/07 Appr

System Type: Bar Splicer

Lenton Form Saver Material marked on the barrel on the sleeve.

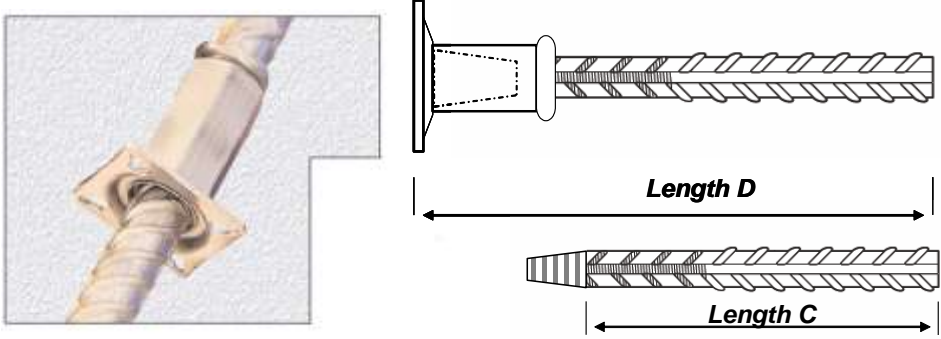

Rebar Designation ASTM		Taper Threaded Rebar (Male) ¹			Coupler/Rebar Assembly (Female) ²		
In-lb	Soft Metric (mm)	Part No.	Length "C" (in) mm		Part No.	Length "D" (in) mm	
4	13	FS4M24	24	610	FS4F20	20	508
		FS4M36	36	914	FS4F24	24	610
5	16	FS5M24	24	610	FS5F24	20	610
		FS5M30	30	762	FS5F30	30	762
		FS5M36	36	914	FS5F36	36	914
6	19	FS6M36	36	914	FS6F24	24	610
		FS7M36	36	914	FS6F36	36	914
		FS7M48	48	1219	FS7F36	36	914
8	25	FS8M48	48	1219	FS8F52	52	1321
9	29	FS9M48	48	1219	FS9F52	52	1321
10	32	FS10M60	60	1524	FS10F64	64	1626
11	36	FS11M60	60	1524	FS11G64	64	1626

P/S#	P/S Name	City, State	Eff Date	Status
------	----------	-------------	----------	--------

2233-02 Erico Products, Inc. Cleveland, OH 04/02/07 Appr

System Type: Mechanical

Erico (CADWELD) T-Series. Part number stamped on splicer sleeve.

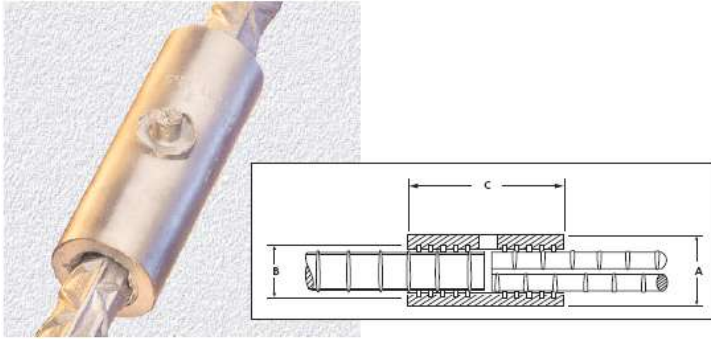

Sleeve Part Number	Size Designation				L		O.D.		I.D.	
	in	mm	Canadian Metric	Soft Metric	in	mm	in	mm	in	mm
RBT1891A (1A)	18	57 mm	55M	57	9 (10)	228.6	3-3/4	95.3	2-5/8	66.7
RBT4558A	---	50 mm	---	50	8	203.2	3-3/8	85.7	2-3/8	60.3
RBT14101A (1A)	14	43 mm	45M	43	7 (8)	177.8	3	76.2	2-1/8	54.0
RBT4117A	---	40 mm	---	40	7	177.8	2-7/8	73.0	2	50.8
RBT12917A	---	38 mm	---	38	7	177.8	2-3/4	69.9	1-7/8	47.6
RBT11101A (1A)	11	36 mm	35M	36	6 (7)	152.4	2-1/2	63.5	1-3/4	44.5
RBT1091A (1A)	10	32 mm	---	32	5-1/2 - 6-1/2	139.7	2-1/4	57.2	1-5/8	41.3
RBT9101A (1A)	9	28 mm	30M	29	5 (6)	127	2-1/8	54.0	1-1/2	38.1
RB8101A (1A)	8	25 mm	25M	25	5 (6)	127	1-7/8	47.6	1-1/4	31.8
RB7101A (1A)	7	22 mm	---	22	5 (6)	127	1-5/8	41.3	1-1/8	28.6
RB6101A (1A)	6	20 mm	20M	19	5 (6)	127	1-1/2	38.1	1	25.4
RBT5101A (1A)	5	16 mm	15M	16	4 (5)	101.6	1-3/8	34.9	7/8	22.2
RBT5101A (1A)	4	12 mm	10M	13	4 (5)	101.6	1-3/8	34.9	7/8	22.2

P/S#	P/S Name	City, State	Eff Date	Status
------	----------	-------------	----------	--------

2233-02 Erico Products, Inc. Cleveland, OH 06/19/09 Appr

System Type: Mechanical

Erico Lenton "P9" & "P14" mechanical splices are stamped with part numbers on the main body

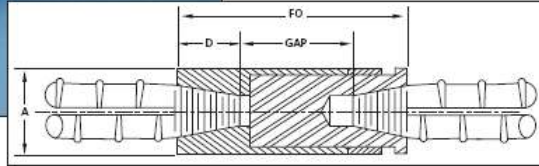

Description

Bar Size	Part No.	"A" Dia.	"D" Dim.	"FO" Dim.	Gap	Weight	Qty/Box	Ends/Chaser*
#4	EL12P14	7/8	19/32	3-1/2	2-3/8	0.5	120	400
#5	EL16P14	1-1/16	15/16	4-1/4	2-1/2	0.9	70	400
#6	EL20P9	1-13/16	1-3/32	4-3/8	2-9/16	2.8	11	360
#7	EL22P9	1-13/16	1-1/4	4-15/32	2-9/16	2.9	12	330
#8	EL25P9	1-13/16	1-3/8	5	2-21/32	3.0	12	300
#9	EL28P9	2-1/2	1-1/2	5-3/16	2-19/32	6.3	6	280
#10	EL32P9	2-1/2	1-9/16	5-7/16	2-21/32	6.3	6	250
#11	EL36P9	2-1/2	1-11/16	5-13/16	2-13/16	6.5	6	230
#14	EL43TP9	3	2-3/16	8-13/16	5-5/32	12.4	4	220
#18	EL57TP9	3-3/4	2-13/16	10-1/2	5-21/32	25.3	2	180

*Approximate based on ELHT100

P/S#	P/S Name	City, State	Eff Date	Status
------	----------	-------------	----------	--------

2233-02	Erico Products, Inc.	Cleveland, OH	10/01/09	Appr
---------	----------------------	---------------	----------	------

System Type: Mechanical

Erico "Lenton Lock" mechanical splices are stamped with part numbers on the main body

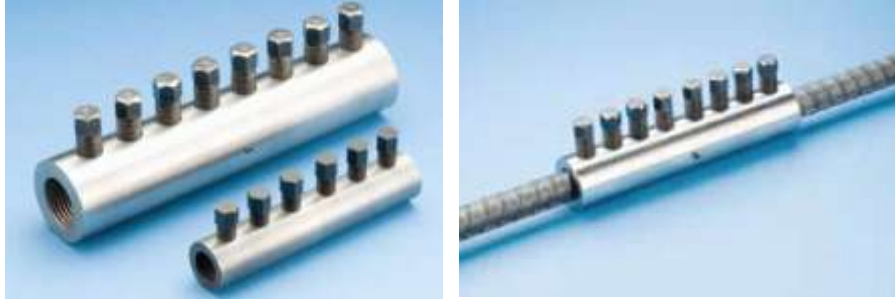

Rebar Designation				Coupler Part Number	Length (L)		Outside Diameter (d)		Inside Diameter		Weight		Socket Size		Average Torque All Bolts		Number of Bolts
Inch-Lb*	Metric*	Canada	Soft Metric		in	mm	in	mm	in	mm	lb	kg	in	mm	ft-lb	N-m	
-	10	-	10	LL12B1	5.0	127	1.1	29	0.6	15	1.2	0.6	1/2	13	150	205	6
#4	12	10 M	13	LL12B1	5.0	127	1.1	29	0.6	15	1.2	0.6	1/2	13	150	205	6
-	14	-	-	LL16B1	6.3	159	1.4	35	0.7	19	2.1	0.9	1/2	13	150	205	6
#5	16	15 M	16	LL16B1	6.3	159	1.4	35	0.7	19	2.1	0.9	1/2	13	150	205	6
-	18	-	-	LL20B1	7.5	191	1.6	41	0.9	24	3.1	1.4	1/2	13	150	205	8
#6	20	20 M	19	LL20B1	7.5	191	1.6	41	0.9	24	3.1	1.4	1/2	13	150	205	8
#7	22	-	22	LL28B1	8.7	222	1.9	48	1.1	28	5.2	2.3	5/8	16	250	340	8
#8	25	25 M	25	LL25B1	10.0	254	2.1	54	1.2	30	7.4	3.4	5/8	16	350	475	8
#9	28	30 M	29	LL28B1	11.3	287	2.4	60	1.3	34	10.2	4.6	5/8	16	350	475	10
-	30	-	-	LL28B1	11.3	287	2.4	60	1.3	34	10.2	4.6	5/8	16	350	475	10
#10	32	-	32	LL32B1	12.7	323	2.6	65	1.5	38	13.1	5.9	13/16	21	500	680	8
-	34	-	-	LL36B1	14.1	358	2.8	72	1.7	43	17.3	7.9	13/16	21	550	750	10
#11	36	35 M	36	LL36B1	14.1	358	2.8	72	1.7	43	17.3	7.9	13/16	21	550	750	10
-	38	-	-	LL40B1	15.7	400	3.1	80	1.9	47	24.0	10.9	13/16	21	580	790	12
-	40	-	-	LL40B1	15.7	400	3.1	80	1.9	47	24.0	10.9	13/16	21	580	790	12

P/S#	P/S Name	City, State	Eff Date	Status
------	----------	-------------	----------	--------

6647-01

6647-01	FABco LLC	Houston, TX	08/26/11	Appr
---------	-----------	-------------	----------	------

System Type: Bar Splicer

FABco Form Saver Coupler with a 2"x2"x1/4" flange.

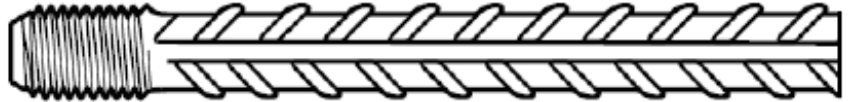
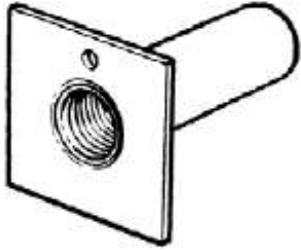

P/S#	P/S Name	City, State	Eff Date	Status
------	----------	-------------	----------	--------

6647-01	FABco LLC	Houston, TX	08/26/11	Appr
---------	-----------	-------------	----------	------

System Type: Bar Splicer

FABco Multiple Piece Tie Bar System

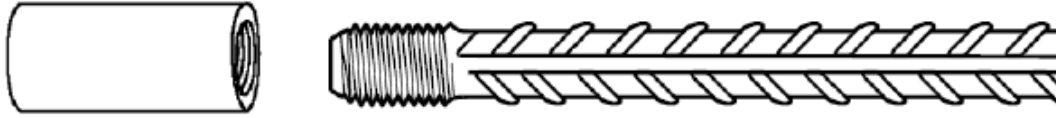

ASTM A-615 Grade 60 Reinforcing Bar Data							
Reinforcing Bar Size	Reinforcing Bar Area	Minimum Yield (lbs.)	Minimum Ultimate (lbs.)	Thread Data	Thread Tensile Area (in ²)	125% f _y Minimum Requirement (lbs.)	Minimum Ultimate Tensile Stress (psi)
#4 [#13]	0.20	12,000	18,000	1/2" - 13 UN	0.1419	15,000	105,708
#5 [#16]	0.31	18,600	27,900	5/8" - 11 UN	0.2260	23,250	102,876
#6 [#19]	0.44	26,400	39,600	3/4" - 10 UN	0.3340	33,000	98,802
#7 [#22]	0.60	36,000	54,000	7/8" - 9 UN	0.4620	45,000	97,403
#8 [25]	0.79	47,400	71,100	1" - 8 UN	0.6060	59,250	97,772
#9 [#29]	1.00	60,000	90,000	1-1/8" - 8 UN	0.7900	75,000	94,937
#10 [#32]	1.27	76,200	114,300	1-1/4" - 8 UN	1.0000	95,250	95,250
#11 [#36]	1.56	93,600	140,400	1-3/8" - 8 UN	1.2330	75,000	94,891
#14 [#43]	2.25	135,000	202,500	1-5/8" 8 UN	1.7800	168,750	94,803

P/S#	P/S Name	City, State	Eff Date	Status
------	----------	-------------	----------	--------

5555-01

5555-01 Fisher Construction Systems, Inc. St. Louis, MO 04/02/07 Appr

System Type: Bar Splicer

FCS is a producer of the Erico Lenton A-2. Part number stamped on splicer sleeve.

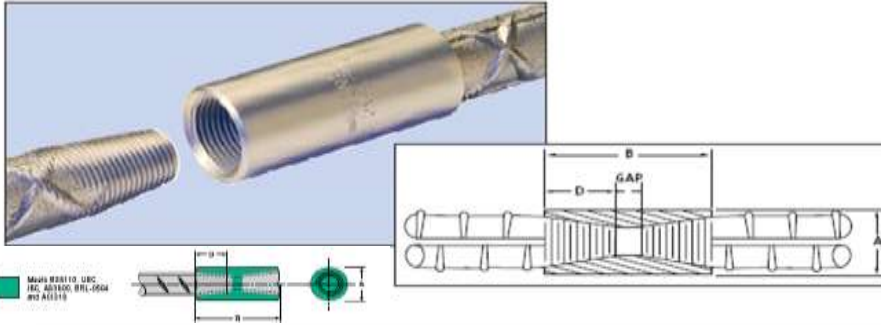

LENTON Standard Couplers - A2												
Inch lb	Rebar Size Metric	Designation Canadian	Soft Metric	Part No.	"A"		"B"		"D"		Weight	
					in	mm	in	mm	in	mm	lb	kg
4	12 mm	10M	13	EL12A2*	11/16	17	1-5/8	41	9/16	14	0.1	0.05
5	16 mm	15M	16	EL16A2*	7/8	22	2-3/16	56	7/8	22	0.3	0.14
6	20 mm	20M	19	EL20A2*	1-1/16	27	2-13/16	71	1-1/8	29	0.5	0.23
7	22 mm	-	22	EL22A2*	1-3/16	30	3-5/32	80	1-1/4	32	0.7	0.32
8	25 mm	25M	25	EL25A2	1-3/8	35	3-11/32	85	1-3/8	35	0.9	0.41
9	28 mm	30M	29	EL28A2	1-1/2	38	3-19/32	91	1-1/2	38	1.1	0.50
10	32 mm	-	32	EL32A2	1-3/4	44	3-25/32	96	1-9/16	40	1.5	0.68
11	36 mm	35M	36	EL36A2	1-7/8	48	3-31/32	101	1-11/16	43	1.7	0.77
-	40 mm	-	-	EL40A2	2-3/16	52	4-15/16	125	2-3/16	56	2.4	1.07
14	43 mm	45M	43	EL43TA2	2-1/4	57	5-1/4	133	2-1/8	54	3.3	1.50
-	50 mm	-	-	EL50A2	2-9/16	64	6-13/32	163	2-13/16	72	4.4	2.00
18	57 mm	55M	57	EL57TA2	3	76	6-1/2	165	2-3/4	70	6.4	3.08

* Use hex material (measured across the flats), others use round material.

Bar dimensions and weights listed may vary by region. Coupler size not shown on these pages are available by special order. Contact your ERICO representative for more information on special sizes. Article numbers used in Europe, Middle East, Africa and Asia exclusively.

P/S#	P/S Name	City, State	Eff Date	Status
------	----------	-------------	----------	--------

5555-01 Fisher Construction Systems, Inc. St. Louis, MO 04/02/07 Appr

System Type: Bar Splicer

FCS is a producer of the Erico Lenton Form Saver Material marked on the barrel on the sleeve.

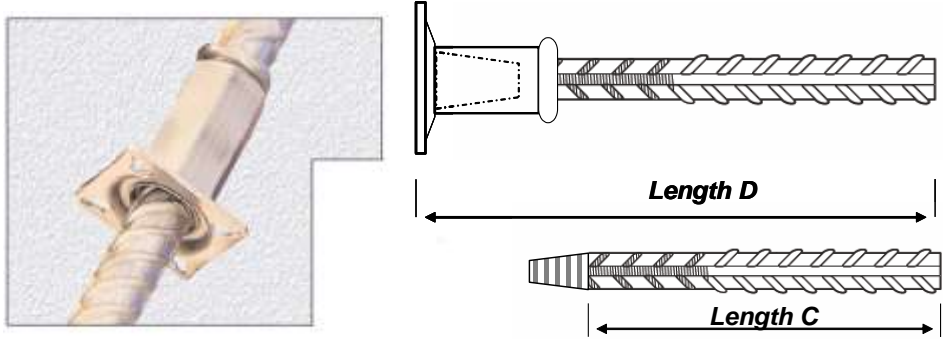

Rebar Designation ASTM		Taper Threaded Rebar (Male) ¹			Coupler/Rebar Assembly (Female) ²		
In-lb	Soft Metric (mm)	Part No.	Length "C" (in) mm		Part No.	Length "D" (in) mm	
4	13	FS4M24	24	610	FS4F20	20	508
		FS4M36	36	914	FS4F24	24	610
5	16	FS5M24	24	610	FS5F24	20	610
		FS5M30	30	762	FS5F30	30	762
		FS5M36	36	914	FS5F36	36	914
6	19	FS6M36	36	914	FS6F24	24	610
		FS7M36	36	914	FS6F36	36	914
		FS7M48	48	1219	FS7F36	36	914
8	25	FS8M48	48	1219	FS8F52	52	1321
9	29	FS9M48	48	1219	FS9F52	52	1321
10	32	FS10M60	60	1524	FS10F64	64	1626
11	36	FS11M60	60	1524	FS11G64	64	1626

P/S#	P/S Name	City, State	Eff Date	Status
------	----------	-------------	----------	--------

5555-01 Fisher Construction Systems, Inc. St. Louis, MO 04/02/07 Appr

System Type: Mechanical

FCS is a producer of the Erico (CADWELD) T-Series. Part number stamped on splicer sleeve.

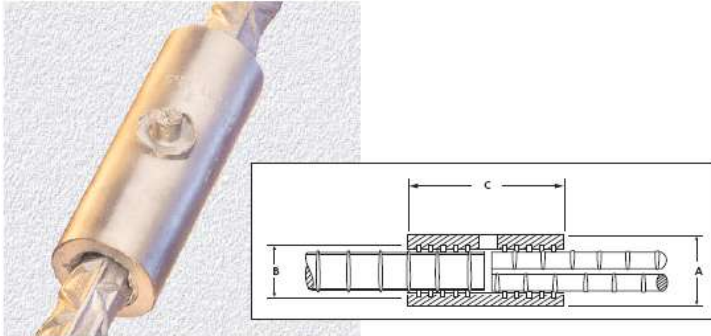

Sleeve Part Number	Size Designation				L		O.D.		I.D.	
	in	Metric	Canadian	Soft Metric	in	mm	in	mm	in	mm
RBT1891A (1A)	18	57 mm	55M	57	9 (10)	228.6	3-3/4	95.3	2-5/8	66.7
RBT4558A	---	50 mm	---	50	8	203.2	3-3/8	85.7	2-3/8	60.3
RBT14101A (1A)	14	43 mm	45M	43	7 (8)	177.8	3	76.2	2-1/8	54.0
RBT4117A	---	40 mm	---	40	7	177.8	2-7/8	73.0	2	50.8
RBT12917A	---	38 mm	---	38	7	177.8	2-3/4	69.9	1-7/8	47.6
RBT11101A (1A)	11	36 mm	35M	36	6 (7)	152.4	2-1/2	63.5	1-3/4	44.5
RBT1091A (1A)	10	32 mm	---	32	5-1/2 - 6-1/2	139.7	2-1/4	57.2	1-5/8	41.3
RBT9101A (1A)	9	28 mm	30M	29	5 (6)	127	2-1/8	54.0	1-1/2	38.1
RB8101A (1A)	8	25 mm	25M	25	5 (6)	127	1-7/8	47.6	1-1/4	31.8
RB7101A (1A)	7	22 mm	---	22	5 (6)	127	1-5/8	41.3	1-1/8	28.6
RB6101A (1A)	6	20 mm	20M	19	5 (6)	127	1-1/2	38.1	1	25.4
RBT5101A (1A)	5	16 mm	15M	16	4 (5)	101.6	1-3/8	34.9	7/8	22.2
RBT5101A (1A)	4	12 mm	10M	13	4 (5)	101.6	1-3/8	34.9	7/8	22.2

P/S#	P/S Name	City, State	Eff Date	Status
------	----------	-------------	----------	--------

5555-01 Fisher Construction Systems, Inc. St. Louis, MO 06/15/09 Appr

System Type: Mechanical

Erico Lenton "P9" & "P14" mechanical splices are stamped with part numbers on the main body

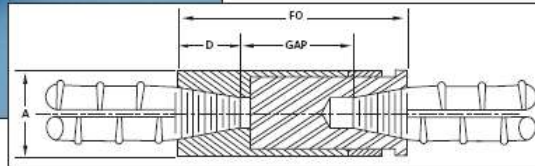

Description

Bar Size	Part No.	"A" Dia.	"D" Dim.	"FO" Dim.	Gap	Weight	Qty/Box	Ends/Chaser*
#4	EL12P14	7/8	19/32	3-1/2	2-3/8	0.5	120	400
#5	EL16P14	1-1/16	15/16	4-1/4	2-1/2	0.9	70	400
#6	EL20P9	1-13/16	1-3/32	4-3/8	2-9/16	2.8	11	360
#7	EL22P9	1-13/16	1-1/4	4-15/32	2-9/16	2.9	12	330
#8	EL25P9	1-13/16	1-3/8	5	2-21/32	3.0	12	300
#9	EL28P9	2-1/2	1-1/2	5-3/16	2-19/32	6.3	6	280
#10	EL32P9	2-1/2	1-9/16	5-7/16	2-21/32	6.3	6	250
#11	EL36P9	2-1/2	1-11/16	5-13/16	2-13/16	6.5	6	230
#14	EL43TP9	3	2-3/16	8-13/16	5-5/32	12.4	4	220
#18	EL57TP9	3-3/4	2-13/16	10-1/2	5-21/32	25.3	2	180

*Approximate based on ELHT100

P/S#	P/S Name	City, State	Eff Date	Status
------	----------	-------------	----------	--------

2918-01

2918-01 Midwet Pipe & Rebar Coating Schererville, IN 04/26/13 Appr

System Type: Bar Splicer

Midwest is a producer of the BPI Standard Barsplicer System from BarSplice Products.

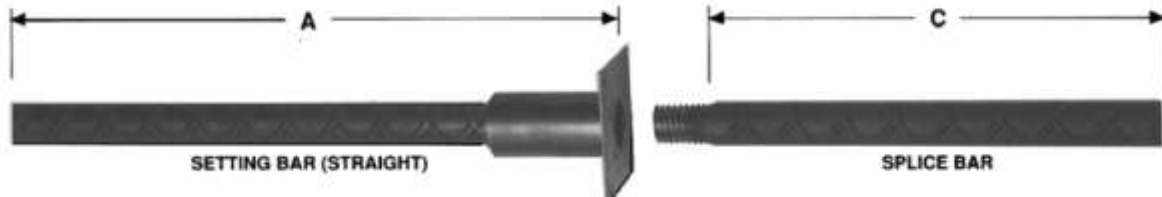

BPI® BARSPLICER FLANGED COUPLER		REBAR SIZE	THREAD SIZE	WEIGHT (lbs)	LENGTH (in)	DIAMETER (in)	FLANGE (in)	BEVEL (in)
	4	½ - 13 UNC	0.28	1 ¾	7/8	2 x 2	-	
	5	5/8 - 11 UNC	0.35	2	1	2 x 2	-	
	6	¾ - 10 UNC	0.40	2 1/8	1 1/8	2 x 2	-	
	7	7/8 - 9 UNC	0.50	2 ½	1 ¼	2 x 2	-	
	8	1 - 8 UNC	0.90	3	1 ½	2 x 2	-	
	9	1 1/8 - 7 UNC	1.50	3 ½	1 ¾	3 x 3	-	
	10	1 ¼ - 7 UNC	2.35	4	2	3 x 3	-	
11	1 ¾ - 6 UNC	2.40	4 ½	2	3 x 3	-		

P/S#	P/S Name	City, State	Eff Date	Status
------	----------	-------------	----------	--------

4225-01

4225-01 Williams Form Engineering Grand Rapids, MI 04/02/07 Appr

System Type: Bar Splicer

C2D Flange use with Williams R4J threaded rebar.

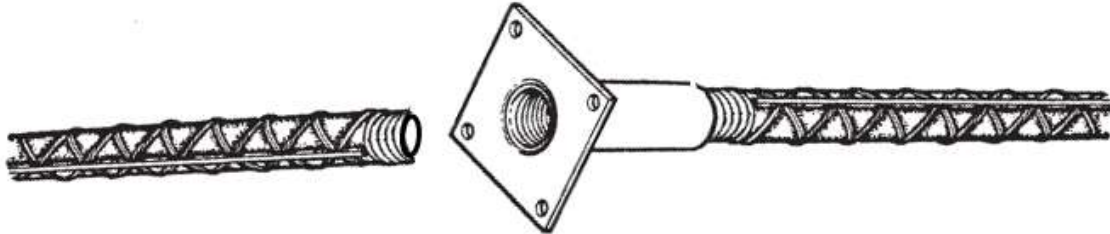

FLANGE COUPLER NO.				
Flange Coupler No.	Thread Size	Flange Coupler O.D. (E)	Flange Coupler Lgth. (C)	Flange Size (F)
4	1/2" -13NC	3/4"	1-1/2"	
5	5/8" -11NC	1"	1-7/8"	2" x 2"
6	3/4" -10NC	1-1/8"	2-1/8"	
7	7/8" -9NC	1-1/4"	2-1/2"	
8	1" -8NC	1-1/2"	3"	
9	1-1/8" -7NC	1-5/8"	3-1/2"	3" x 3"
10	1-1/4" -7NC	1-7/8"	3-3/4"	
11	1-3/8" -8UN	2-1/8"	4"	
14	1-3/4" -5NC	2-3/4"	5"	4" x 4"

*Flange Coupler is manufactured from steel specification ASTM A-108
 For coupling rebar without flange, see C1T, C2T couplings on pages 12 and 13.

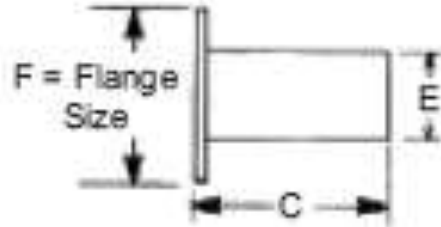

Illinois Department of Transportation
Bureau of Materials and Physical Research

Submittal for Testing and Approval

Effective: July, 27, 2007

A. Scope

Before materials can be used for a Department project, the manufacturer/supplier must have a producer/supplier number assigned to their facility. The following guidelines are provided to clarify the submittal requirements and expedite the process.

B. Procedure

When requesting producer/supplier status with the Department, the following shall be included in the certification:

- Manufacturer name and internet address (if applicable),
- The specific product brand name, (if private label must provide original product name)
- Material Safety Data Sheet (if applicable),
- Technical Data Sheet,
- A signed letter stating the subject material will not be changed without written notification to the Department, and
- Contact person's name, title, address, email address, and phone number.

Depending on the material, test samples may be required to obtain a producer/supplier number. Please contact Ed Hughes at 217-782-4689 for sample size as sizes vary depending on the material type. The sample and certification shall be sent to:

Ed Hughes
Illinois Department of Transportation
Bureau of Materials & Physical Research
126 East Ash Street
Springfield, IL 62704-4766

Any sample provided without the required information listed will not be tested. Any changes outside the manufacturer's original parameters will necessitate a new sample submittal.

Submitted materials will be tested according to the Department's current edition of the Standard Specifications for Road and Bridge Construction.

C. Recertification

Annual recertification for various materials is required. During the last quarter of the calendar year, a recertification letter will be sent to the manufacturer. The recertification paperwork is due by mid January of the following year. The recertification process assures the manufacturer that his/her product will remain on the approved list for a period of one calendar year.

The manufacturer will be notified when the sample testing is complete. For questions regarding the testing and approval process, contact Ed Hughes at 217-782-4689.

Illinois Department of Transportation
Bureau of Materials and Physical Research

Submittal for Testing and Approval

Effective: July, 27, 2007

Instructions for Acknowledgement by Company:

The owner, partner, or corporate officer shall complete the following and return a signed and dated copy with the product submittal or recertification.

_____ desires to obtain approval of materials to be
(Insert name of company)
supplied to Department of Transportation contractors as more fully described herein. I
and _____ understand that the Department of Transportation
(Insert name of company)
reserves the right in its contracts to approve materials at the source of supply as
provided in Article 106.01 of the Standard Specifications for Road and Bridge
Construction. I and _____ further understand that approval of
(Insert name of company)
company supplied material pursuant to this request does not constitute a contract to
supply material to the State of Illinois or any of its contractors, and that the Department
of Transportation does not assure or guarantee that any materials approved hereunder
will be supplied to the State or any of its contractors. In consideration of approval, I and
_____ agree to the terms, conditions and performance
(Insert name of company)
standards of the Standard Specifications for Road and Bridge Construction.

Type of Company: Individual Partnership Corporation

Company Name _____

Printed Name _____

Signature _____

Title _____

Business Address _____

City/State/Zip Code _____

Date of Signature _____