

PIPE DIA.	THICKNESS	DIMENSIONS					SLOPE (Approx.) (V:H)	BODY
		A	B	H	L	W		
12 (300)	0.064 (1.63)	1± (25)	6 (150)	6 (150)	1± (25)	1½± (38)	2± (50)	1 Pc.
15 (375)	0.064 (1.63)	7 (180)	8 (205)	6 (150)	26 (660)	30 (760)	1:2½	1 Pc.
18 (450)	0.064 (1.63)	8 (205)	10 (255)	6 (150)	31 (785)	36 (915)	1:2½	1 Pc.
21 (525)	0.064 (1.63)	9 (230)	12 (305)	6 (150)	36 (915)	42 (1,065 m)	1:2½	1 Pc.
24 (600)	0.064 (1.63)	10 (255)	13 (330)	6 (150)	41 (1,040 m)	48 (1,220 m)	1:2½	1 Pc.
30 (750)	0.079 (2.01)	12 (305)	16 (405)	8 (205)	51 (1,295 m)	60 (1,525 m)	1:2½	1 Pc.
36 (900)	0.079 (2.01)	14 (355)	19 (480)	9 (230)	60 (1,525 m)	72 (1,830 m)	1:2½	2 Pc.
42 (1050)	0.109 (2.77)	16 (405)	22 (560)	11 (280)	69 (1,750 m)	84 (2,135 m)	1:2½	2 Pc.
48 (1200)	0.109 (2.77)	18 (455)	27 (685)	12 (305)	78 (1,980 m)	90 (2,285 m)	1:2¼	2 Pc.
54 (1350)	0.109 (2.77)	18 (455)	30 (760)	12 (305)	84 (2,135 m)	102 (2,590 m)	1:2	2 Pc.
60 (1500)	0.109 (2.77)	18 (455)	33 (840)	12 (305)	87 (2,210 m)	114 (2,895 m)	1:1¾	3 Pc.
66 (1650)	0.109 (2.77)	18 (455)	36 (915)	12 (305)	87 (2,210 m)	120 (3,050 m)	1:1½	3 Pc.
72 (1800)	0.109 (2.77)	18 (455)	39 (990)	12 (305)	87 (2,210 m)	126 (3,200 m)	1:1⅓	3 Pc.
78 (1950)	0.109 (2.77)	18 (455)	42 (1,065 m)	12 (305)	87 (2,210 m)	132 (3,355 m)	1:1¼	3 Pc.
84 (2250)	0.109 (2.77)	18 (455)	45 (1,145 m)	12 (305)	87 (2,210 m)	138 (3,505 m)	1:1⅓	3 Pc.

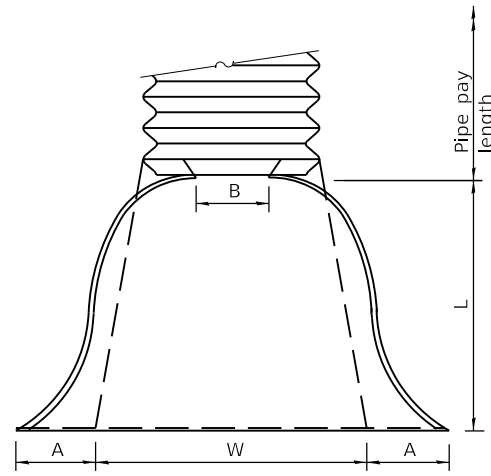

PLAN

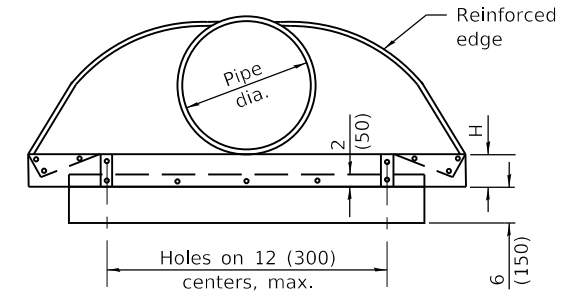

END VIEW

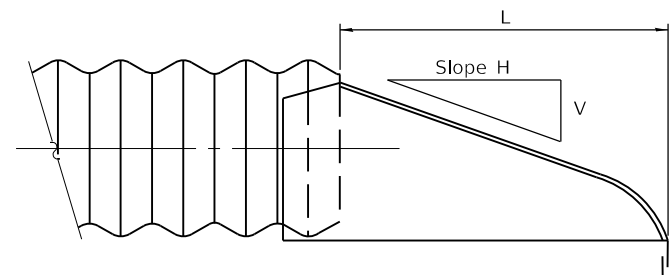

SIDE VIEW

END SECTION

NOTES

For 60 (1500) thru 84 (2250) sizes, reinforced edges shall be supplemented with stiffener angles. The angles shall be 2x2x¼(51x51x6.4) for 60 (1500) thru 72 (1800) diameter and 2½x2½x¼ (64x64x6.4) for 78 (1950) thru 84 (2250) diameter. The angles shall be attached by ⅝ (M10) rivets or bolts.

All slope ratios are expressed as units of vertical displacement to units of horizontal displacement (V:H).

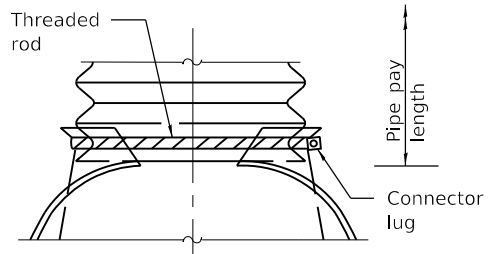

TYPE 1

For 12 (300) thru 24 (600) only (See Note 1)

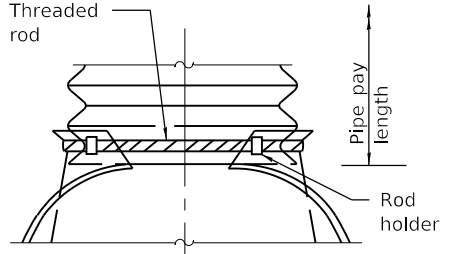

TYPE 2

For 30 (750) and 36 (900) only (See Note 1)

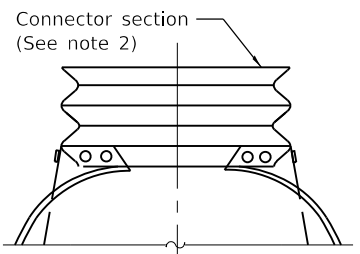

TYPE 3

(See Note 2)

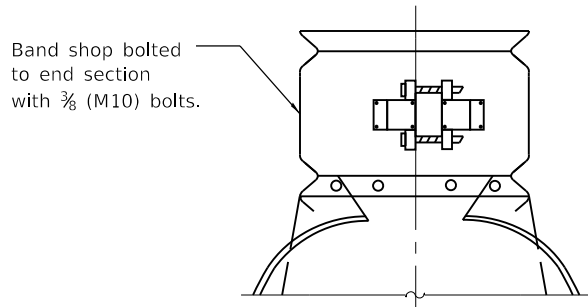

TYPE 4

(See Note 3)

NOTES

- Types 1 and 2 for pipes with annular ends only.
- Type 3 connection may be used for all pipe sizes and includes 12 (300) of the pipe length. The connector section shall be attached to the end section by rivets or bolts and shall be the same metal thickness as the end section. Stub shall be either 2⅔ (68) pitch x ½ (13) depth or 3 (75) pitch x 1 (25) depth annular corrugated pipe.
- Type 4 connection can be used for all pipe sizes. Coupler shall be 2⅔ x ½ (68x13) dimple, hugger, or annular band of 3x1 (75x25). The dimple, hugger, or annular band may be used with corrugated metal pipes having annular ends. For corrugated metal pipes having helical ends, only the dimple band will be allowed.

All dimensions are in inches (millimeters) unless otherwise shown.

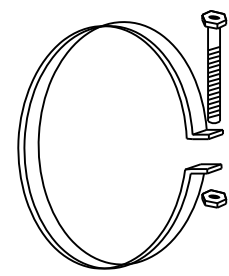

ALTERNATE STRAP CONNECTOR

(For Type 1 only)

1 (25) wide, 0.109 (2.77) thick strap with standard ½x6 (M12x150) band bolt and nut.

CONNECTIONS OF END SECTIONS

DATE	REVISIONS
1-1-21	Revised THICKNESS values in table.
1-1-18	Renamed standard.

METAL FLARED END SECTION FOR PIPE CULVERTS

STANDARD 542401-04

Illinois Department of Transportation

PASSED January 1, 2021

 ENGINEER OF POLICY AND PROCEDURES

APPROVED January 1, 2021

 ENGINEER OF DESIGN AND ENVIRONMENT

ISSUED 1-1-97