

DETAIL A

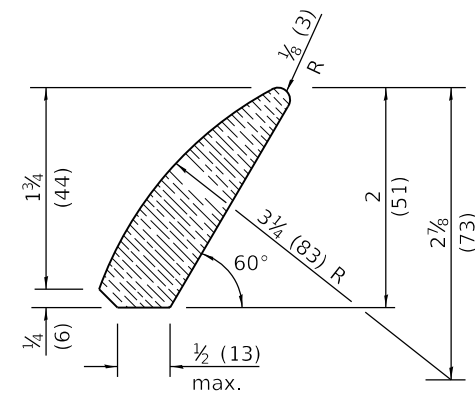

DETAIL B

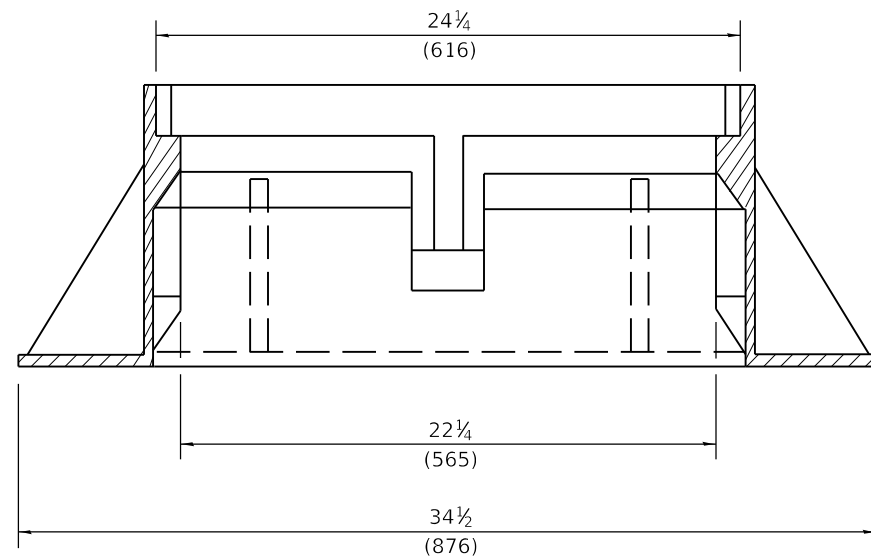

SECTION D-D

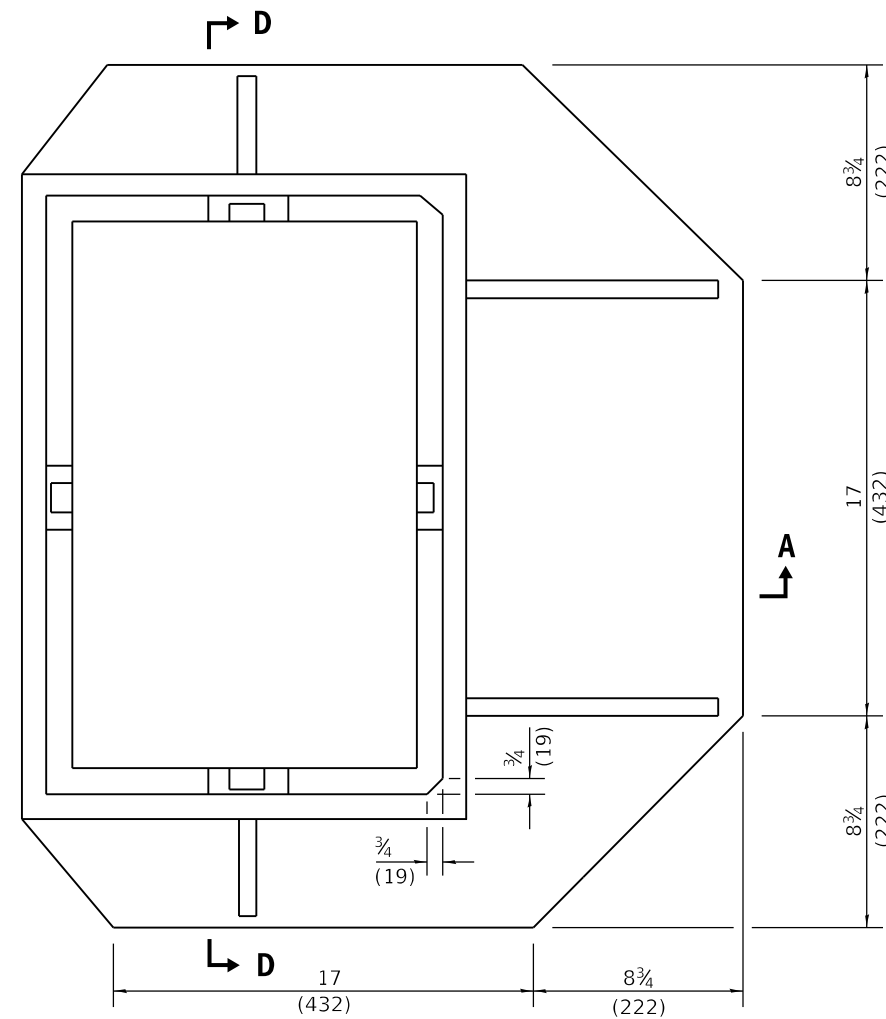

PLAN - FRAME

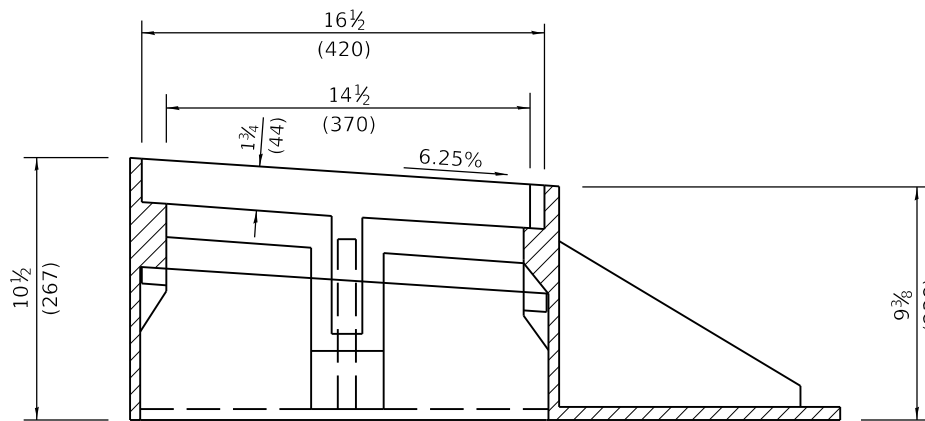

SECTION A-A

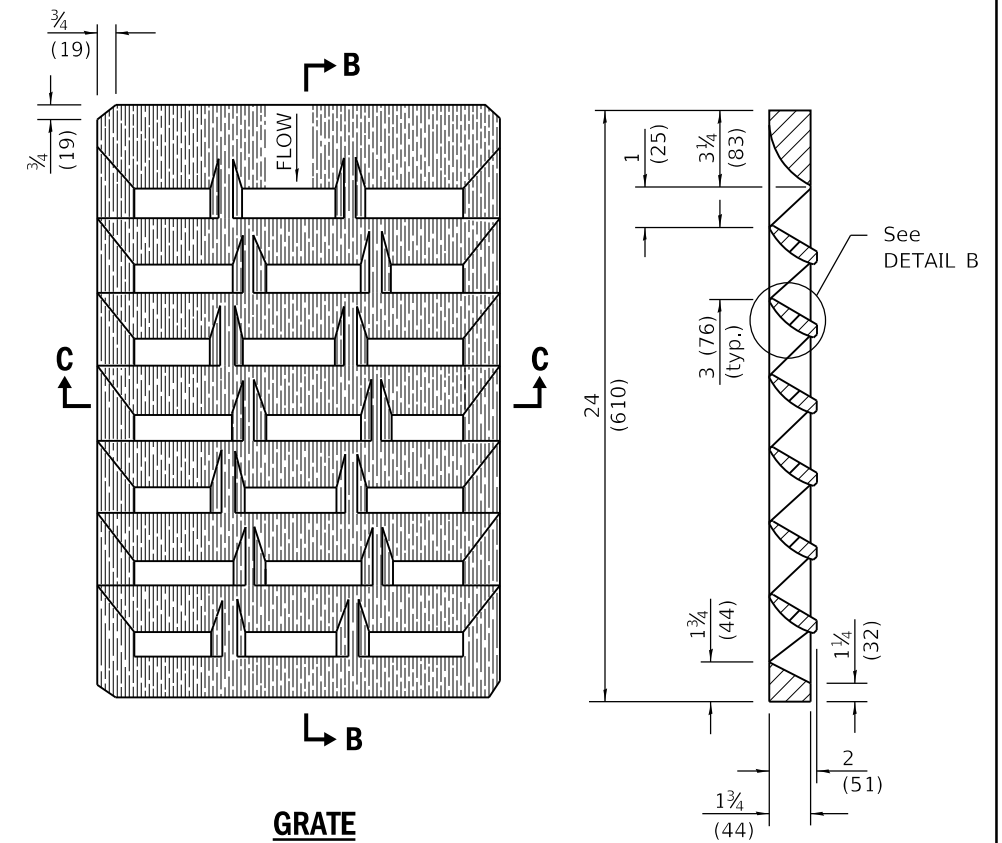

GRATE

SECTION B-B

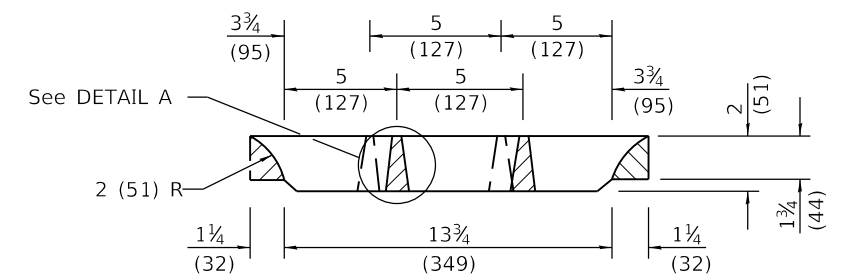

SECTION C-C

All dimensions are in inches (millimeters) unless otherwise shown.

Illinois Department of Transportation

PASSED January 1, 2021
Michael Bond
 ENGINEER OF POLICY AND PROCEDURES

APPROVED January 1, 2021
J. E. ...
 ENGINEER OF DESIGN AND ENVIRONMENT

ISSUED 1-1-2021

DATE	REVISIONS
1-1-21	Removed "safety bars" from frame.
1-1-15	Revised dimensions of frame.

**FRAME AND GRATE
TYPE 23**

STANDARD 604086-04