

PLAN

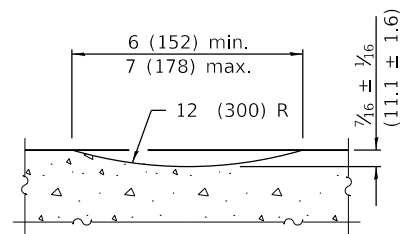

SECTION A-A

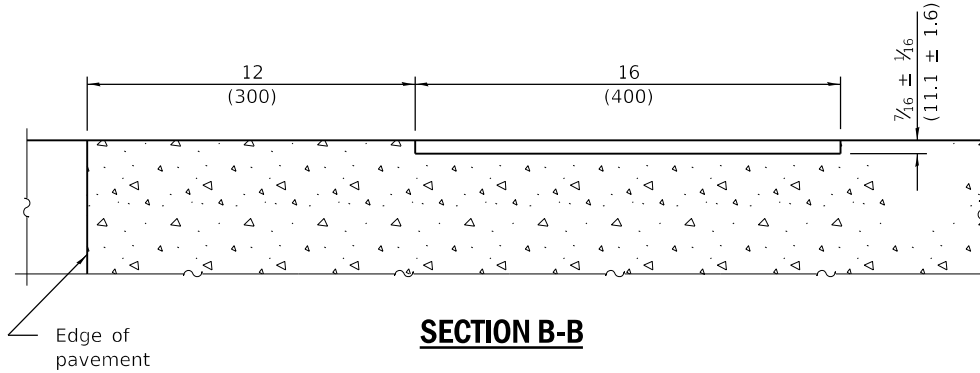

SECTION B-B

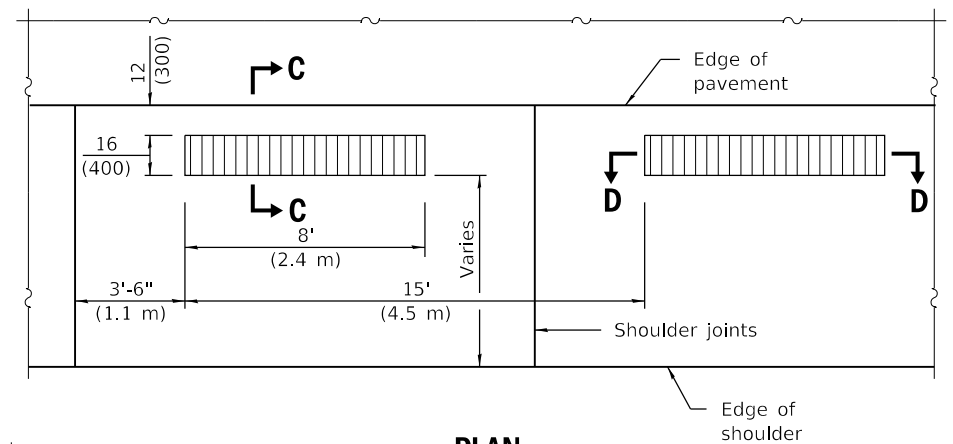

PLAN
(Formed Alternate for PCC Shoulders)

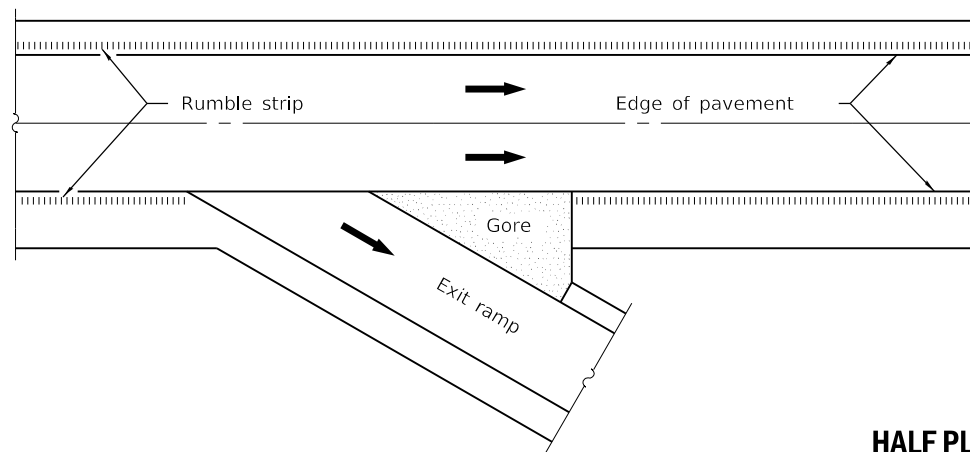

HALF PLAN
TYPICAL APPLICATION AT AN INTERCHANGE

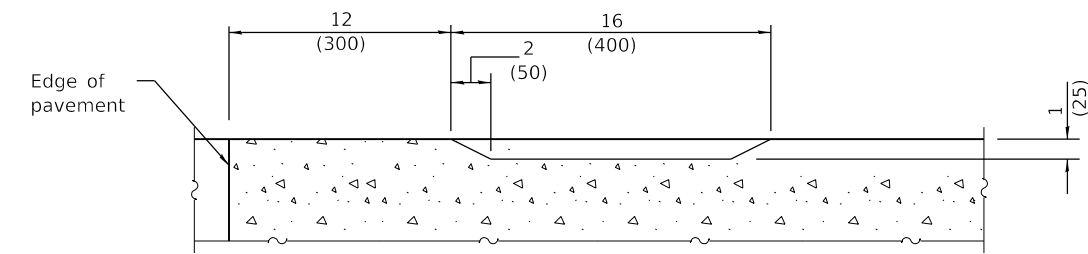
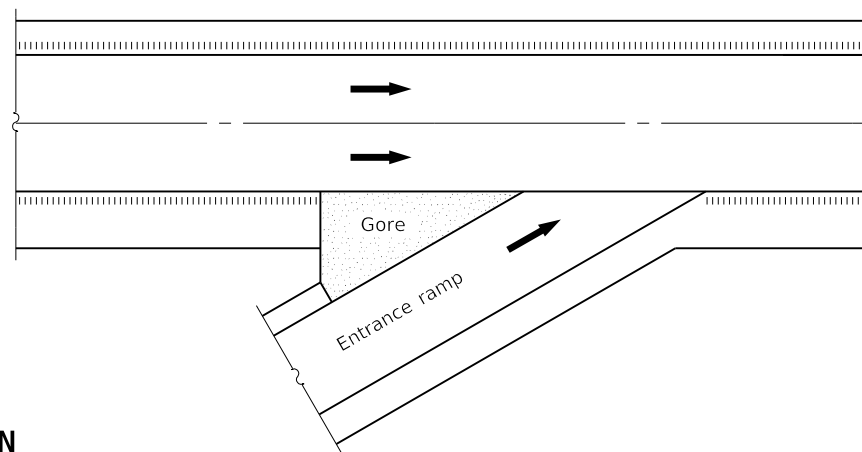

SECTION C-C

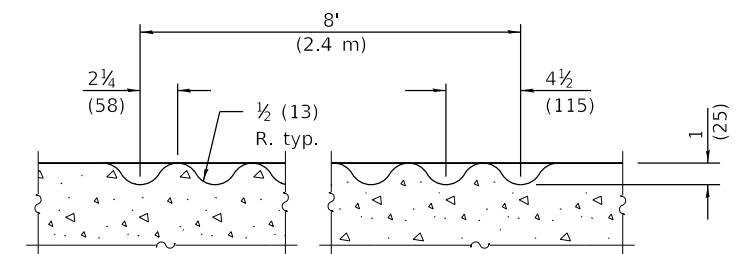

SECTION D-D

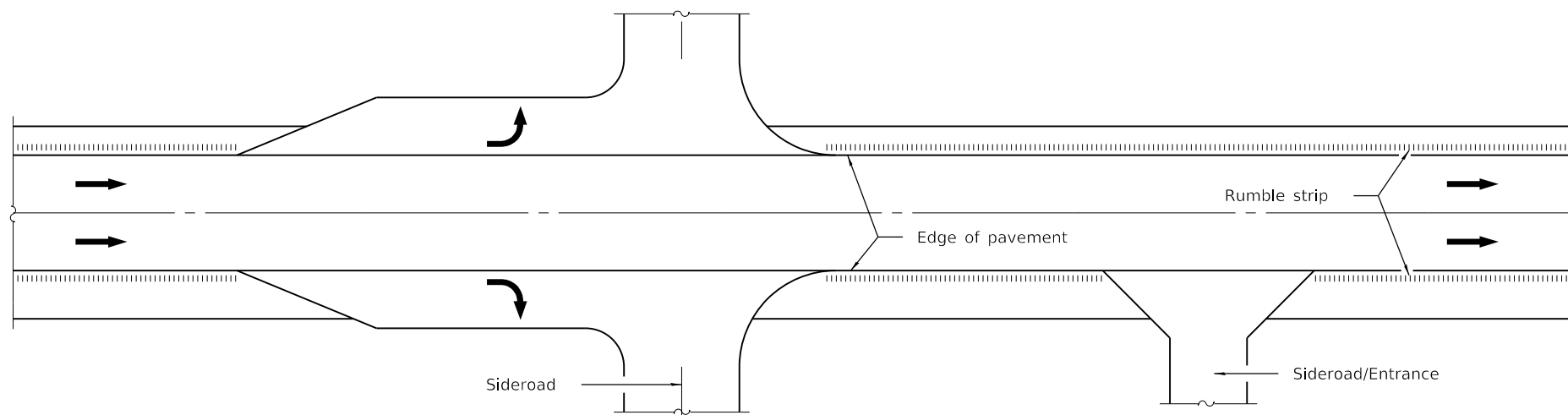

HALF PLAN
TYPICAL APPLICATION AT AN INTERSECTION OR ENTRANCE

GENERAL NOTES

On Portland cement concrete shoulders, no shoulder rumble strip shall be located closer than 6 (150) to a transverse joint.

Omit shoulder rumble strips across structures.

All dimensions are in inches (millimeters) unless otherwise shown.

DATE	REVISIONS
1-1-12	Changed formed rumble strip to 16 (400) wide. Rev'd milled strip. Renamed standard.
1-1-09	Switched units to English (metric).

SHOULDER RUMBLE STRIPS, 16 in.

STANDARD 642001-02

Illinois Department of Transportation

PASSED January 1, 2012
Michael Beard
 ENGINEER OF POLICY AND PROCEDURES

APPROVED January 1, 2012
Scott Schick
 ENGINEER OF DESIGN AND ENVIRONMENT

ISSUED 1-1-03