

* This distance shall be adjusted to place the transverse expansion joint in prolongation with the existing joint in the mainline pavement.

Longitudinal sawed joint or a longitudinal construction joint with No. 6 (No. 19) tie bars at 36 (900) cts. for a distance of 100' (30 m) beginning at the 24 (600) stub. Joint line is parallel to ramp baseline.

Pavement thickness and joint type in the ramp taper, for a distance of 950' (290 m), shall be the same as the mainline. Joints shall be in prolongation with mainline pavement joints.

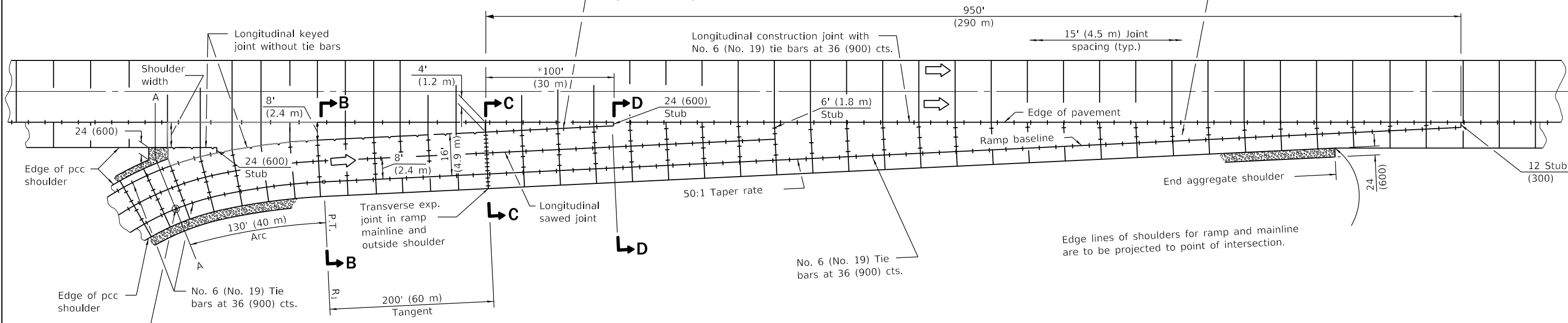

PLAN

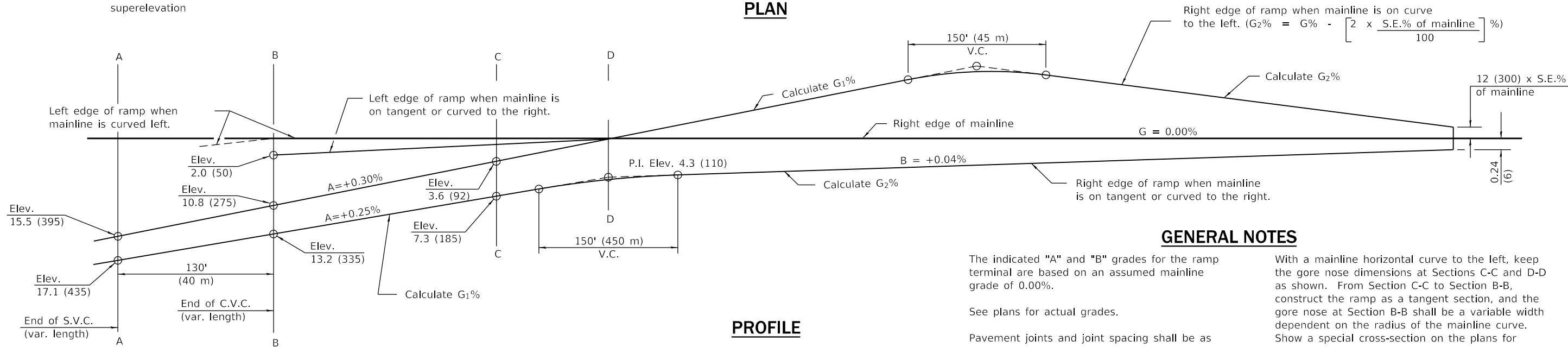

PROFILE

GENERAL NOTES

The indicated "A" and "B" grades for the ramp terminal are based on an assumed mainline grade of 0.00%.

See plans for actual grades.

Pavement joints and joint spacing shall be as shown on Standards 420001, 420101 and 420106.

See Standard 483001 for ramp shoulder details.

Between Sections A-A and B-B (shaded area), provide a drainage swale and flush inlet to enhance drainage.

When using grades expressed in %, the grade value shall be divided by 100 to obtain vertical offsets.

When using radius R1 less than the minimum, verify the required acceleration length will be provided.

With a mainline horizontal curve to the left, keep the gore nose dimensions at Sections C-C and D-D as shown. From Section C-C to Section B-B, construct the ramp as a tangent section, and the gore nose at Section B-B shall be a variable width dependent on the radius of the mainline curve. Show a special cross-section on the plans for Section B-B.

With a mainline horizontal curve to the right, keep the gore nose dimensions at Sections D-D, C-C, and B-B as shown, and the edge of the ramp between Sections C-C and B-B is constructed as a compound curve tying Section C-C.

All dimensions are in inches (millimeters) unless otherwise shown.

DATE	REVISIONS
1-1-22	Revised General Note for joints and joint spacing.
1-1-18	Changed tie bar spacing to 36 (900) cts.

ENTRANCE RAMP TERMINAL
(JOINTED PCC RAMP PAVEMENT ADJACENT TO JOINTED PCC MAINLINE PAVEMENT)

(Sheet 1 of 2)

STANDARD 420201-12

Illinois Department of Transportation

PASSED January 1, 2022
Michael Beard
 ENGINEER OF POLICY AND PROCEDURES

APPROVED January 1, 2022
John C. ...
 ENGINEER OF DESIGN AND ENVIRONMENT

ISSUED 1-1-97

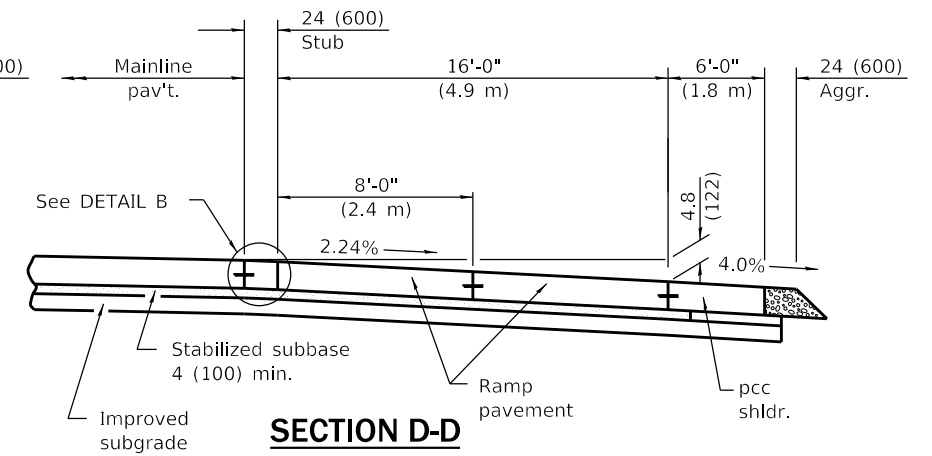
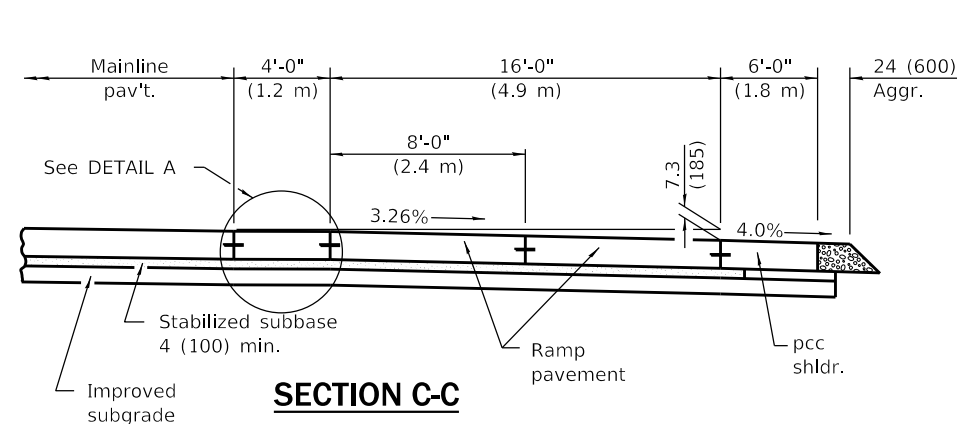
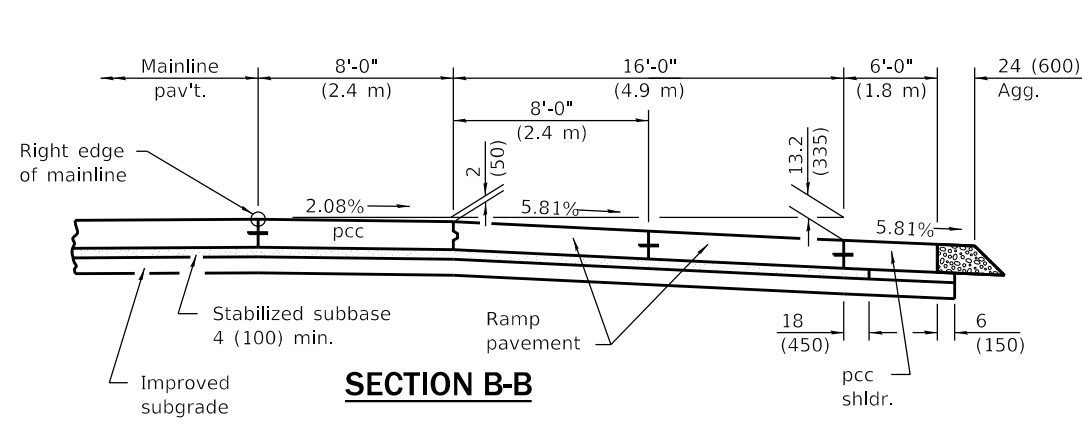

CROSS SECTIONS WHEN MAINLINE IS ON TANGENT OR CURVED TO THE RIGHT

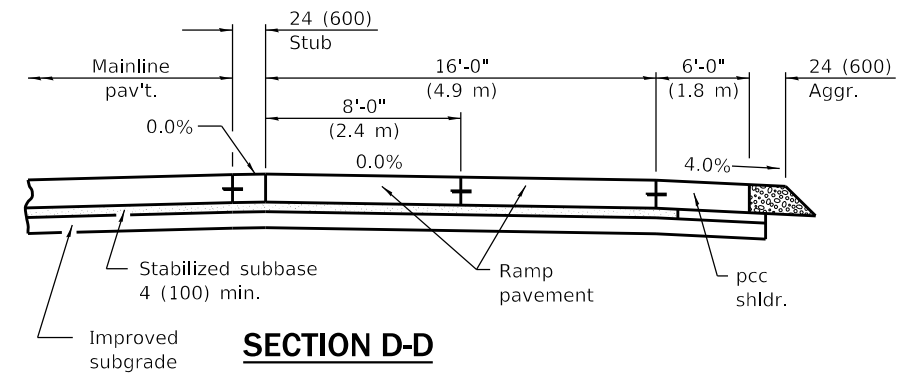
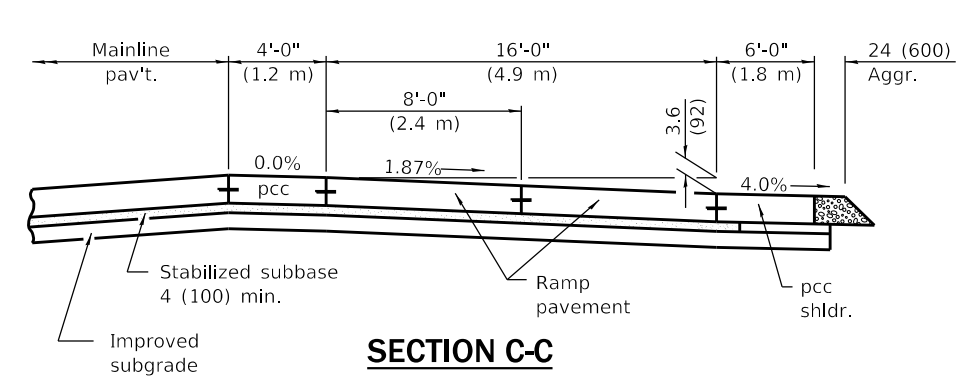
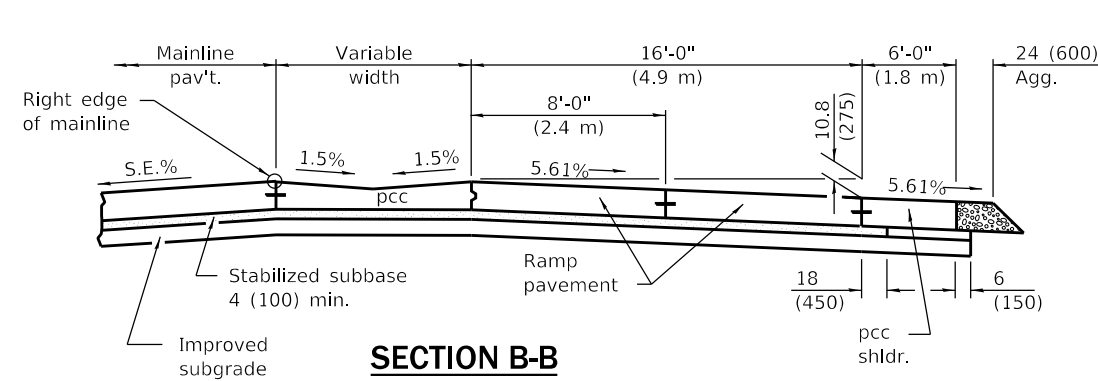

CROSS SECTIONS WHEN MAINLINE IS CURVED TO THE LEFT

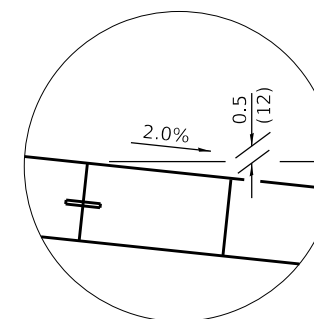
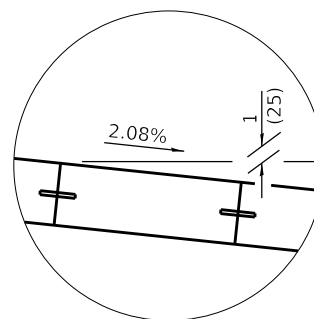

DETAIL A

DETAIL B

Illinois Department of Transportation
 PASSED January 1, 2022
 Michael Beard
 ENGINEER OF POLICY AND PROCEDURES
 APPROVED January 1, 2022
 S. J. C. H.
 ENGINEER OF DESIGN AND ENVIRONMENT
 ISSUED 1-1-97

ENTRANCE RAMP TERMINAL
 (JOINTED PCC RAMP PAVEMENT ADJACENT TO
 JOINTED PCC MAINLINE PAVEMENT)
 (Sheet 2 of 2)
STANDARD 420201-12